

Masport[®] **Heating**

MYSTIQUE Installation & Operations Manual



**THIS MANUAL CONTAINS IMPORTANT INFORMATION.
PLEASE KEEP IT IN A SAFE PLACE FOR FUTURE REFERENCE.**

Manufactured in New Zealand by:
GLEN DIMPLEX NEW ZEALAND LIMITED
P.O.Box 58473, Botany, Manukau - 2163
Ph: 0800 666 2824
Fax: 09 274 8472
Email: sales@glendimplex.co.nz
Web: www.glendimplex.co.nz

1st Mar 2017

Part No. 598640 V1.5

*Glen Dimplex New Zealand Ltd reserves the right to change specifications, content of this manual or design of its product without prior notice.

CONTENTS

	PAGE
1.0 INTRODUCTION	3
1.1 ITEMS SUPPLIED WITH THE FIRE	3
1.2 HANDLING AND TRANSPORT	3
1.3 WARNINGS	4
1.4 CAUTIONS	4
2.0 TECHNICAL SPECIFICATIONS	5
3.0 INSTALLATION OF THE FIRE	6
3.1 UNPACKING	6
3.2 POSITIONING	6
3.3 FLUE REQUIREMENTS	6
3.4 FLOOR PROTECTOR REQUIREMENTS	7
3.5 SEISMIC RESTRAINT	7
3.6 REDUCING CLEARANCES	7
4.0 PERMITTED FUELS	9
4.1 TESTING YOUR WOOD	9
4.2 RECOMMENDED FUEL LOG SIZES	9
5.0 OPERATIONAL SEQUENCE	10
5.1 BEFORE FIRST LIGHT-UP	10
5.2 COLD START-UP	10
5.3 STACK & LIGHT KINDLING	10
5.4 INTERMEDIATE LOAD 1	10
5.5 INTERMEDIATE LOAD 2	11
5.6 RE-FUELING	11
5.7 FAN OPERATION	12
5.8 SHUT DOWN & RESTART	12
6.0 CLEANING AND MAINTENANCE	13
6.1 PERIODIC CLEANING & CHECK	13
6.2 ANNUAL MAINTENANCE	13
7.0 ELECTRICAL & ELECTRONICS CONTROLS	15
7.1 FAN OPEATION	15
7.2 FAN MAINTENANCE	15
7.3 ELECTRONIC CONTROL	15
7.4 ELECTRICAL DIAGRAMS	15
8.0 MYSTIQUE REPLACEMENT PARTS	16
9.0 TROUBLESHOOTING: CAUSES & REMEDY	17
10.0 MYSTIQUE WARRANTY	18

1.0 Introduction

Congratulations! You are the owner of a state-of-the-art Ultra Low Emission Burner “**Masport Mystique**” designed and developed by Glen Dimplex New Zealand. Thank you for purchasing a Masport appliance.

MYSTIQUE burner is a new generation wood fire, designed to provide you with all the warmth and charm of a fireplace, at the same time have negligible emissions with dramatically reduced impact on the environment. This model has been approved by Environment Canterbury for installation in all of their clean air zones that have been banned for installation of a conventional wood burner. As it bears the Masport brand, it promises to provide you with economy, safety and efficiency.

To make the most of your appliance, it is important to install, operate and maintain the burner correctly. Please read this installation and operations manual carefully before installing or operating your MYSTIQUE fire. Please take time to understand the basic principles of this new burner which uses down draft combustion technique. .

Conventional Masport burner has a single firebox and uses triple combustion technique with preheated combustion air. Injection of preheated air jets in different direction bombards the fire bed and creates a very hot turbulent flame to burn most of the polluting particles at around 600~700°C. Though this is a clean way of burning, some particulate and valuable heat energy escapes to atmosphere through an exhaust flue pipe.

Mystique burner has a firebox with two combustion chambers and a heat exchanger at the rear of these two chambers. Fuel is loaded and ignited in the top combustion chamber where primary combustion takes place. After initial primary burning, when the overall burner is hot enough and sustained flue draft is created, flue gases are directed downward into bottom combustion chamber by closing the damper in upper section of the firebox. The exhaust gases passing through the red hot embers get re-ignited and burns at temperature higher than 1000°C. The extreme hot temperatures and turbulence created while passing through ember bed, burns almost all the particulate matter. Further, these hot gases passes through a heat exchanger to extract maximum heat from the exhaust gases and reduces its temperature down to 250°C. Overall, the result of this downdraft combustion technique is very efficient burning with maximum heat with less fuel consumption and negligible emissions.

1.1 Items supplied with the fire

- Mystique Burner
- 600mm Mystique St/St Double Skin Flue Shield
- Accessory Pack – which contains
 - 1 x 4mm Allen Key for bottom combustion chamber
 - 1 x Installation and Operations Manual
 - 1 x Seismic bracket
 - 1 x ceramic block

1.2 Handling and Transport

The MYSTIQUE fire is heavy and tall in size with total weight of 175 kgs.

Single person handling could cause injury, hence Masport recommends suitable handling equipment or two persons while handling, both outside and inside the house.

All precautions have been taken during designing of packaging so that the fire reaches customer's house without any damage. In case any damage is found while opening the fire, please report it to your dealer and to Masport immediately before installing the fire.

1.3 Warnings

- The installation of Mystique burner requires a building consent prior to installation commencing. Check with your local Building Authority whether there are any extra requirements before commencing installation.
- The Mystique burner and flue system shall be installed in accordance with AS/NZS 2918:2001 and appropriate requirements of the relevant local building codes.
- Glen Dimplex highly recommends NZHHA trained SFAIT (Solid Fuel Appliance Installation technician) installer for installation of Mystique burner. Your dealer or heating specialist will be able to help with recommendations as well as advice on permits/consents required for the installation in your area.
- Please read carefully all the dimensions and recommendations provided on the technical specification section of this manual. The dimensions given comply with required safety standard AS/NZS 2918:2001.
- Mystique has both electrical and electronic parts. The appliance is designed to work as plug-n-play. But any electrical work required to connect to main power or any maintenance work must be carried out by a licensed electrician.
- Safety and emissions performance of MYSTIQUE can be affected by altering the appliance hence no modifications are allowed without written permission from the manufacturer.
- Please ensure that only components approved by Glen Dimplex New Zealand are used for the installation, as substitutes may adversely affect performance and might nullify compliance with the requirements of AS/NZS 2918 safety standard.
- Mystique burner should be installed with a Masport flue system.
- Modifying the dimensional specification of components may result in hazardous conditions. Where such action is considered, the manufacturer should be consulted in the first instance.
- In order to meet consent regulation of the Environment Canterbury Regional Council and Glen Dimplex's Warranty terms, Mystique burner must be serviced at least once every 2 years from service agent trained and authorized by Glen Dimplex New Zealand.

1.4 Caution

- This appliance is not intended for use by persons (including children) with reduced physical, sensory or mental capabilities, or lack of experience and knowledge, unless they have been given supervision or instruction concerning use of the appliance by a person responsible for their safety.
- Do not leave children un-attended near alighted fire and keep them well away from the fire when in use. Supervise young children to ensure that they do not play with the appliance.
- Do not use flammable liquids or aerosols to start or rekindle the fire. Also do not use such flammable materials in the vicinity of this appliance when it is operating.
- Always keep clothing, firewood, furnishing and other combustible materials at a safe distance from the fire.
- Do not attempt to open the bottom door when fire is in use.
- Do not touch any part of the fire other than the top door and the damper handle when in use as all other parts can be extremely hot.
- Cracked/broken door glass, makes the installation unsafe. Do not operate the fire with cracked glass.
- Do not attempt to clean or maintain the fire when in use or with hot embers in top or bottom combustion chamber. Ensure that embers and all other parts of the fire have cooled down completely and the fire is isolated from the main electrical power supply.
- Do not use the fire if there is a malfunction, a suspicion of breakage or unusual noises. Contact your nearest Masport dealer or customer service team at Glen Dimplex New Zealand.
- This appliance should be operated & maintained at all times as per instructions given in this manual.

Failure to follow above warnings, cautionary measures and instruction given in this installation and operation manual will void the Masport warranty of this product.

2.0 Mystique Technical Specifications

Mystique fire has been tested and complies to following standards & tests :
Environment Canterbury's Real life test - Canterbury test method CM1
NZ National Environmental Test Standards - AS/NZS 4012:2015 and AS/NZS 4013:2015.
NZ National Environmental Safety Test Standard - AS/NZS 2918:2001

Overall Dimensions	470mm Wide x 545mm Deep x 1170mm High		
Weight	175.0 kg		
Test Method	Emissions mg/MJ	Emissions g/kg	Efficiency %
Real Life Test Canterbury Method	19 mg/MJ	0.30 g/kg	78%
National Environment Standard AS/NZS 4012/13:2015	11 mg/MJ	0.17 g/kg	75.7%
Heat Output	Power in kW		
Minimum Average Output	8 kW		
Maximum Average Output	10.2 kW		
Peak Observed during Tests	16.2 kW		
Flue Shield	600mm Long SS Masport Double Flue Shield		
Flue System	Std 4.2M Long, 150mm Masport Flue System		
Floor Protector Requirement	Ash Floor Protector		

Clearances to Combustibles

Parallel Installation

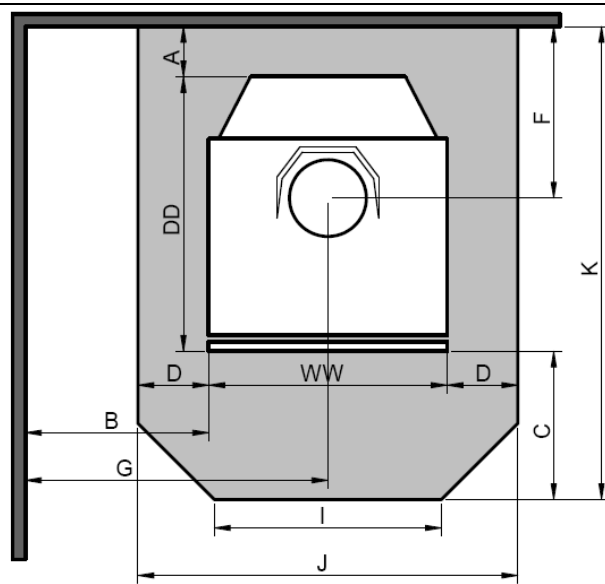

Corner Installation

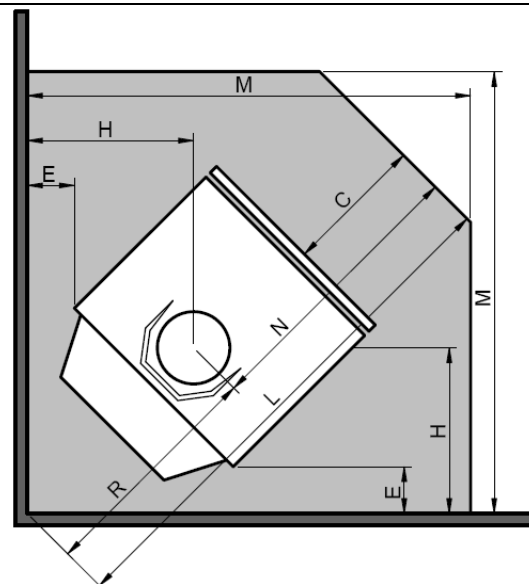

A- Rear Panel to Rear Wall	100 mm	C- Glass to Floor Protector Front	300 mm
B-Cooktop Edge to Side Wall	360 mm	E- Cooktop Corner to Wall	100 mm
C- Glass to Floor Protector Front	300 mm	H- Flue Centre to Wall	350 mm
D- Floor Protector Side	138 mm	L- Floor Protector Diagonal	1095 mm
F- Flue Centre to Rear Wall	344 mm	M- Floor Protector Side	932 mm
G- Flue Centre to Side Wall	595 mm	N- Flue Centre to Floor Protector Front	601 mm
I- Floor Protector Front Edge	446 mm	R- Flue Centre to Wall Corner	494 mm
J- Floor Protector Width	746 mm	WW- Overall Width of Fire	470 mm
K- Floor Protector Depth	945 mm	DD- Overall Depth of Fire	545 mm
		HH- Overall Height of Fire	1170 mm

3.0 Installation of Mystique

3.1 Unpacking

Remove the shipping wooden crate and packing around the burner. Remove the packers and other loose pieces from the firebox. Remove and discard the screws holding the wood fire to the shipping pallet. Using appropriate lifting equipment, move the burner close to its installation position. Correct lifting procedures should be observed to avoid injury while handling Masport Mystique burner.

3.2 Positioning

Mystique burner is tested to a parallel or corner wall configuration, with minimum distances to heat sensitive materials in accordance with the AS/NZ 2918:2001 safety test standard. Determine the installation position for your Mystique fire only after considering the necessary clearances (See Technical Specifications on page 5 of this manual) and checking the practicability of installing the flue system. No wall or other fixed object should be closer to the front of the Mystique burner than two meters. Regard heat resistant walls with heat sensitive surface treatments (e.g. wallpaper or heat sensitive paints) as heat sensitive walls.

Any proposed deviation from the specified clearances or installation configurations should be discussed with a registered "NZHHA" approved installer or GDNZ's technical team, thus ensuring that progression thereafter is in accordance with the guidelines in the AS/NZ 2918:2001 test standard and subsequently no compromise on safety.

3.3 Flue Requirements

Standard 4.2M long, 150mm diameter Masport flue systems which has been tested and complies with the current installation standard AS/NZS 2918:2001 Appendix F shall be used for Mystique burner along with the 600mm long, Masport St/St double skin flue shield. Clearances to combustibles given on section 2.0 have been determined during safety test which was carried out with standard parallel and corner installation configuration with minimum 2.4m high ceiling.

If a flue exits out of the roof within 3 meters from the ridge, the outer shield shall be not less than 600mm above the ridge. If the flue exits further than 3 meters out from the roof ridge then it must project at least 1000mm above roof penetration. This dimension may need increasing to ensure that the top of the flue is at least 3 meters away from the roof or other obstruction when measured horizontally.

The flue pipe shall extend not less than 4.2m above the top of the burner. Due to factors such as roof pitch, predominant winds, nearby obstructions (i.e. trees, buildings) and fire placement, flue lengths and flue terminations/cowls may vary. (Refer Figure 3.3.1) Additional components may be required to complete the installation and meet all AS/NZS 2918:2001 guidelines for flue termination.

AS/NZS2918:2001 guidelines should be followed for any deviation to these standard configurations. **Detailed instructions for roof penetrations etc. are supplied along with the Masport flue kit.** These must be followed closely, including the minimum flue exit height from the top of the floor protector and the minimum exit height above the roofline or roof ridge as detailed in the instructions.

Flue installations other than strictly vertical ones are possible. See AS/NZS 2918:2001 for information on non-vertical flues and flues passing through walls and eaves.

The flue to the flue spigot and all other flue pipe joints should be sealed using firebox cement. Sealing all the joints is important for achieving desired performance of the Mystique burner.

If a flue heat shields other than tested or mentioned in the specifications section 2.0 is used, the installation clearances will be in accordance with the guidelines specified in AS/NZS 2918:2001 for an untested flue installations.

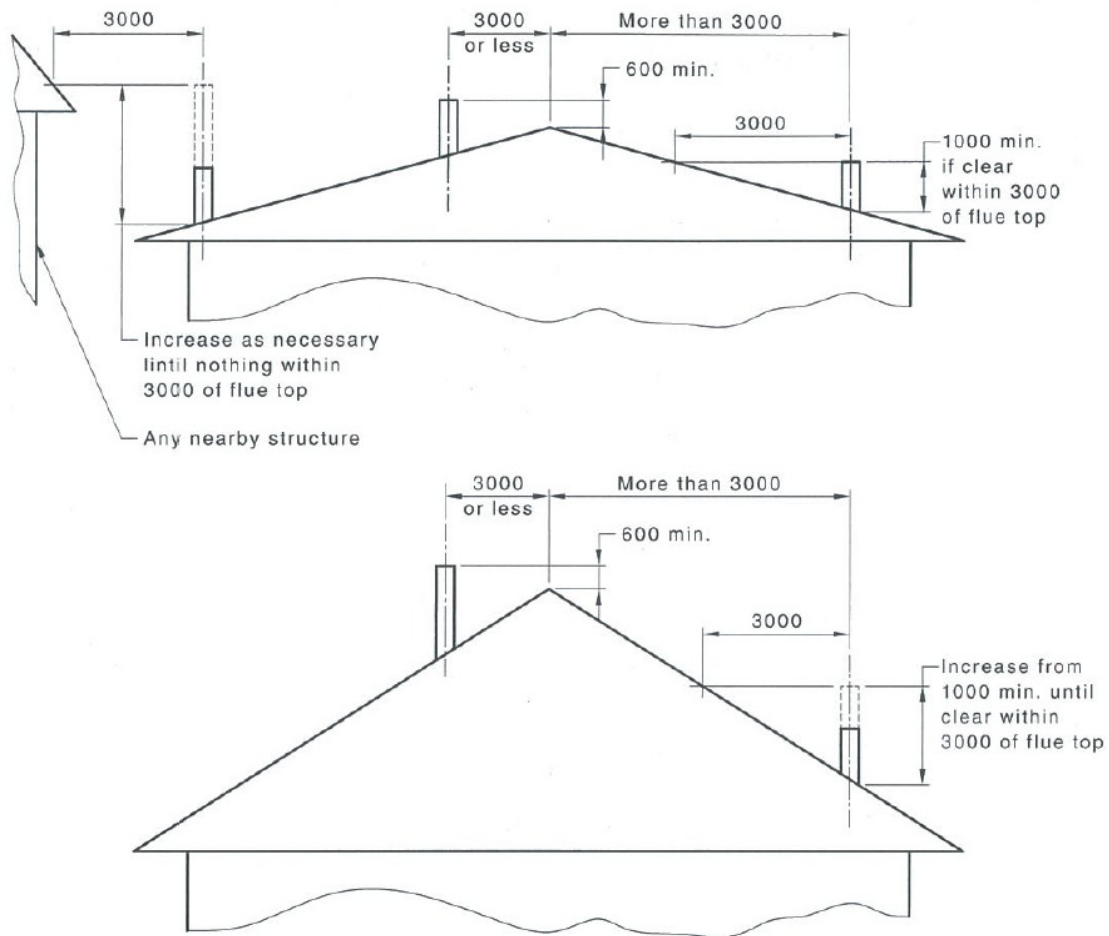

Figure 3.3.1

3.4 Floor Protector Requirements

Mystique burner can be installed on any non-combustible ash floor protector with minimum dimensions given on page 4 of this manual. Please note that the dimensions given are minimum and we recommend to use slightly larger floor protector size.

Please note that the Mystique burner is heavy having total weight of 175 Kg. The floor and the materials used as floor protector should be strong enough to bear this load. The minimum requirements for material to be used as floor protectors on a combustible materials are

- 6mm fibre cement board (e.g. Hardies Tile & Slate Underlay) plus 8mm ceramic tiles on a firm base.
- 4mm mild steel floor protector supplied by Glen Dimplex
- Or equivalent.

3.5 Seismic Restraint

Mystique burner must be seismically restrained, including the floor protector. The Fig 3.5.1 gives the holes that can be pre-drilled on the floor protector with respect to flue centre.

We recommend a minimum 8mm dynabolt or 8mm coach screws for wooden floors of appropriate length.

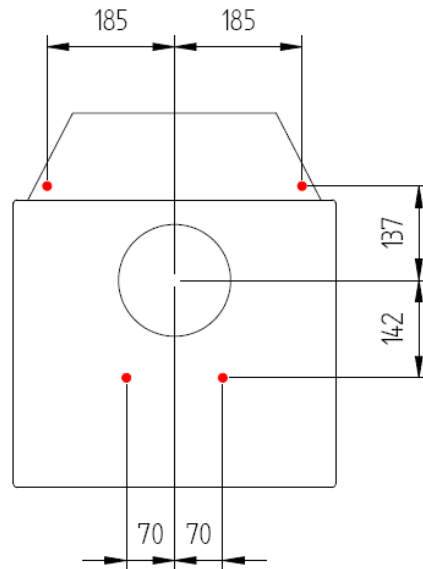

Fig. 3.5.1

3.6 Reducing Clearances

The clearances to combustible specified in section 2.0 of this manual, can be safely reduced by following guidelines specified in AS/NZS 2918:2001 table 3.1 & 3.2.

- Heat shield should be made of non-combustible material like metal or masonry.
- Installed between burner and the combustible wall
- With an air gap behind it and vented top and bottom
- The shield should extend a minimum of 450mm beyond the top of the appliance and extend width-wise so that unshielded rear clearance is maintained

Clearance factors for heat shield which is within 45 degrees of the vertical

Heat Shield Construction	Minimum Air Gap Dimension	Clearance Factor
Single layer of continuous material	12mm	0.4
Single layer of continuous material	25mm	0.3
Two spaced layers of continuous material	12mm+12mm	0.2

Clearance factors for heat shield which is more than 45 degrees off the vertical

Heat Shield Construction	Minimum Air Gap Dimension	Clearance Factor
Single layer of continuous material	12mm	0.8
Single layer of continuous material	25mm	0.6

4.0 Permitted Fuels

The quality of the firewood you burn can have a considerable effect on performance of the MYSTIQUE burner. Moisture content, tree species and log size are the main factors that affects the emissions that are produced by any wood burner. We recommend that firewood with less than 25% moisture content be used.

If you are cutting your own firewood, only wood that has been air dried in a sheltered, well ventilated stack, preferably for at least 12 months may be burned in MYSTIQUE. To ensure that the wood has a moisture content of 25% or less, store it under a roof or protected against heavy rain. If you purchase firewood, buy firewood that is well seasoned and having moisture level below 25%. We recommend “Good Wood” merchants approved by your local council.

In any case do not burn coal, driftwood, treated or painted wood, highly resinous wood like “Old Man’s Pine”, laminated plastics, plywood, chipboard, garbage, flammable fluids such as gasoline, naphtha, engine oil, refuse, milk cartons, colored or printed paper. Use of such materials will invalidate your warranty, as this may emit toxic, corrosive and hazardous fumes when burned. They may also cause a build-up of the toxic gas dioxin, which is damaging to the burner and the environment. Most importantly, use of such materials will invalidate your warranty.

4.1 Testing Your Wood Moisture

There are number of ways to confirm if wood is dry enough.

- Wood moisture meter is the best way to check the moisture content of the wood fuel. Press the meter tip into wood firmly into the long side of a split piece of wood and test it. The 15-25% percent moisture content is ideal.
- If you are purchasing firewood, ask for dry seasoned wood and get it tested from your wood merchant.
- Dry wood weighs much less than wet wood.
- Wet wood is hard to light and will emit moisture from the ends while burning.
- Two dry pieces banged together sound hollow, wet pieces sound solid and dull.

4.2 Recommended Log Sizes & Fire Starters

- A packet of matches or lighter
- A packet of firelighters. We recommend green firelighters made of wood waste
- Seasoned firewood about 220~250mm long in various sizes
 - o (2A) For kindling - 15-16 finely split, dry softwood (total 1.0 kg approximately)
 - o (2B) For intermediate 1 load – 4 pieces (total 1.2 kg, 300 g each approximately)
 - o (2C) For intermediate 2 load – 4 pieces (total 2.5 kg, 625 g each approximately)
 - o (2D) For main load – 3 or more pieces (Total 3.0 kg, 1 kg each approximately)

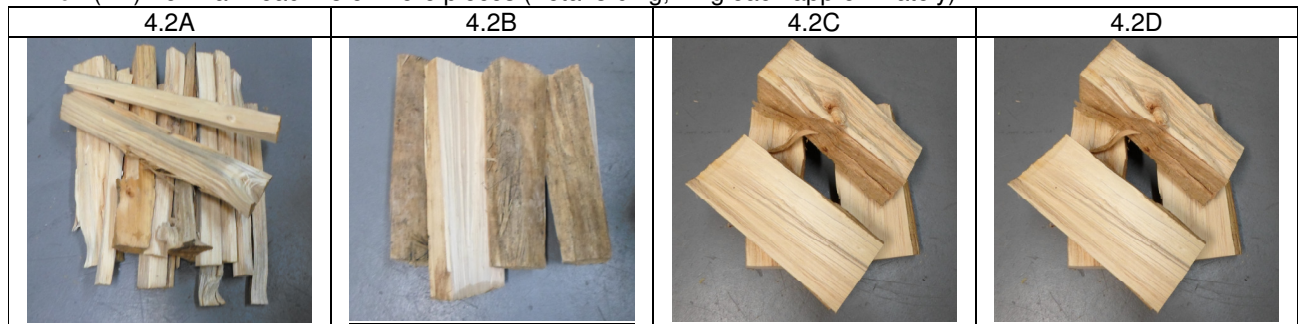

5.0 Operational Sequence (For various steps refer images shown in the bracket)

5.1 Before First Light-up

- Make sure that the burner is correctly installed and signed off by an approved installer.
- All local council's wood fire permission or permit requirements have been completed satisfactorily.
- Make sure that all the packing material has been removed from both the combustion chambers.

Please note that the special high temperature paint is used in the firebox that will emit some smoke as it cures during initial two to three sessions of running. Ventilate the house during these initial burns. While curing the surface heated paint softens, so do not touch hot surface during this process. Babies, small children, pregnant women, elderly persons, persons subject to pulmonary hypersensitivity and pets should avoid exposure to this smoke. Open doors and windows and use a fan, if necessary. After these initial burns, there should be no smoke.

5.2 Cold Start- up

- (5.2A) Make sure the bottom combustion chamber door is closed and ceramic block is sitting in place at the rear of the chamber
- (5.2B) The burner is connected mains power and Fan switch is in the "ON" position
- (5.2C) The LED on the front bottom panel should be "RED"
- (5.2D) Set the damper handle to "OPEN" position

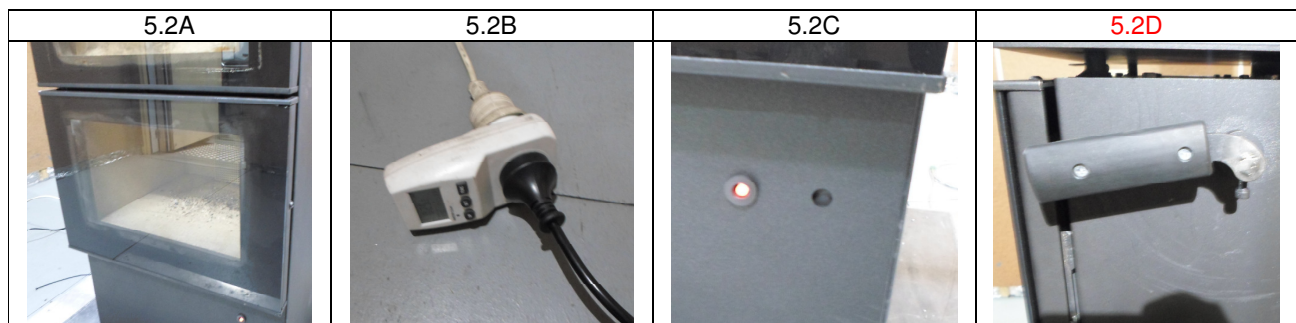

5.3 Stack & Light Kindling

- (5.3A) Open the top combustion chamber & Load 4 pieces of kindling around & top of the downdraft injector.
- (5.3B) Place 2 firelighters as shown
- (5.3C) Load the remaining kindling over the firelighters in stack formation
- (5.3D) Light the fire starters and close the door



5.4 Intermediate Load 1 & Green LED

- (5.4A & 5.4B) In about 4-5 mins, kindling will be fully alight. Open the door, add 4 pieces of intermediate 1 load – approx. 1.2 kg and then close the door.
- Now onwards, always ensure that all fuel logs are loaded with "Front to Back" orientation with slightly at an angle in the firebox.
- (5.4C) in about 10-12 mins, the "GREEN" LED will light when an optimum conditions are reached for the downdraft operation mode.
- (5.4D) Turn damper handle from "Open" to "Close". This sets the burner into downdraft mode.

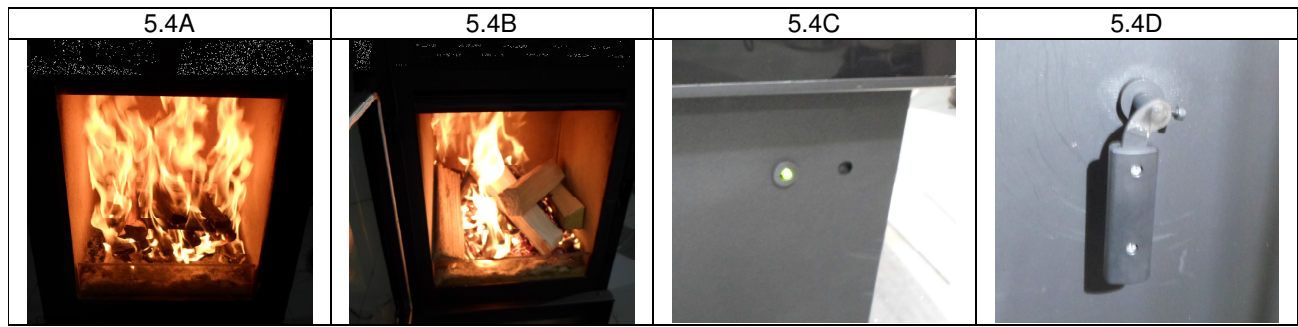

5.5 Intermediate Load 2 & Door Operations

- (5.5A) Door will not open once damper handle is positioned on “Close” because of safety interlock mechanism.
- (5.5B) The downdraft flame in the bottom combustion chamber should look like this.
- When approx. 50% of the intermediated load 1 has burned down, Turn the damper handle to “Open” positions
- (5.5C) Open the top combustion chamber, load 4 pieces intermediate 2 load – approx. 2.5 kg and close the door
- (5.5D) Turn the damper handle to “Close” position to set the burner back into downdraft mode.
- **Do not ever force to open the top chamber door when damper is in “Close” position**
- Please note if the bottom chamber flame is ‘pulsing’ or ‘puffing’ after closing the damper, open the damper for another 1-2 mins and then close to return to downdraft mode.

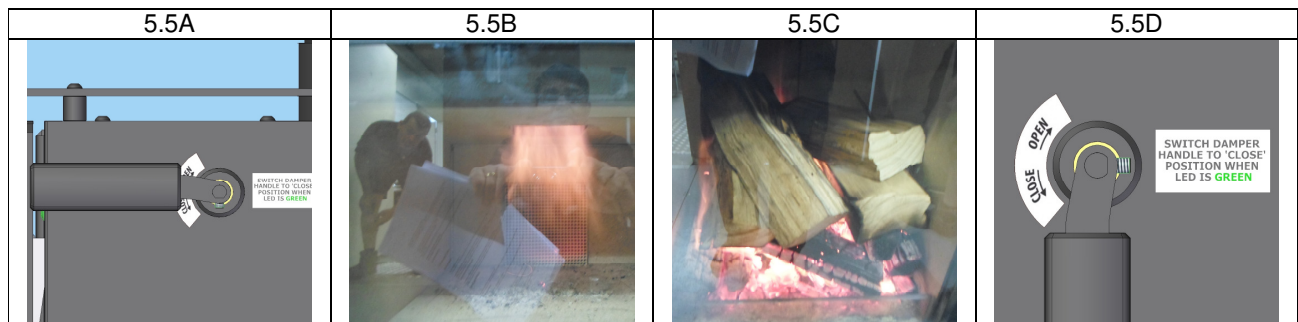

Overall the above steps should take around 40-45 mins. This point on, the burner will be hot enough to run the in downdraft mode for prolonged period.

5.6 Re-fueling

- (Burner can be refueled with bigger logs once the down-draft is fully established.
- (5.6A) As fuel burns away the down-draft flame will reduce. This is normal and flame will increase again when more fuel is loaded.
- (5.6B) Turn damper handle to “Open” position, open the top combustion chamber.
- Use rake and level the ember bed. Particularly leaving good embers around the downdraft injector.
- (5.6C) Place the 2-3 large size logs weighing approximately 1 kg each on embers in Front-to-Back direction.
- Close the door
- (5.6D) If the “Green” is still alight, turn the damper handle to “Close” position to continue downdraft mode.

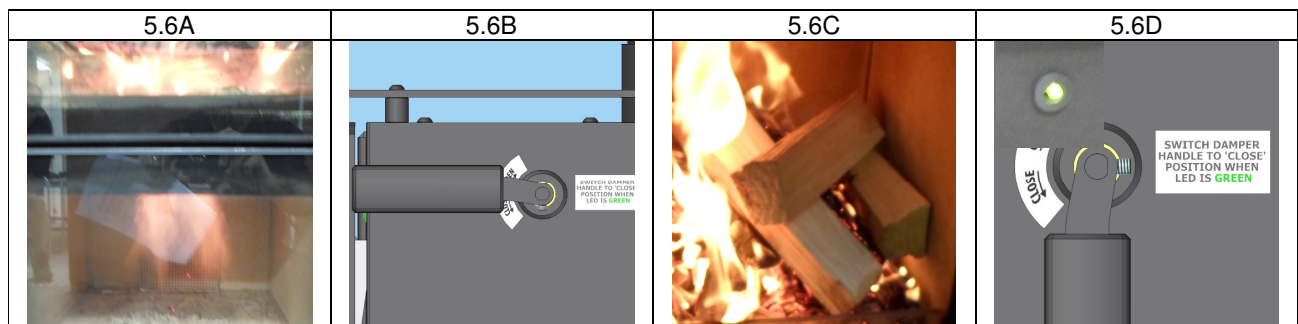

5.7 Fan Operation

- Keep the fire connected to power supply all the time and fan switch to "ON" position, all the time.
- Fan will switch "On/Off" automatically as per set temperatures of the rear of the firebox.
- Please note that in case of emergency and power outage situations, burner can be operated without fan.
- While running the burner without power, there will be no LED to indicate that the firebox has reached optimum conditions for down draft mode. Hence ensure that damper handle is turned to "Close" position approx. 15 mins after the light-up, which is the optimum point for switching.

5.8 Shut-down and Restart

- To shut down the burner, let the fire extinguish and leave the burner doors closed until it has cooled down
- The fan will stop automatically when the firebox has cooled to certain level
- Also the LED will turn "RED" as the fire cool down.

6.0 Cleaning and Maintenance

The following precautions must be taken prior to start any cleaning or maintenance activity:

- **Make sure there are no burning embers in the top or bottom chamber and ashes have cooled down completely.**
- **Make sure that all panels of the burner are cold**
- **Make sure you have isolated the burner from main electrical power supply.**

6.1 Periodic Cleaning & Checks

Depending upon the usage certain parts or areas of the Mystique burner will need cleaning every week or fortnight.

6.1.1 Ash Removal

The downdraft burner creates considerably less ash compared to conventional wood burners. Depending upon usage, ash removal will be required every week or as required.

- Open the top combustion chamber door and & remove the top downdraft injector by lifting vertically.
- Using a small brush, push accumulated ash into bottom chamber through injector hole.
- Open the bottom chamber door using tool provided with the fire.
- Insert a metal pan into the lower combustion chamber and using a small brush swap ash on to pan.
- Remove the metal pan with ash and empty it.
- Carefully put back the downdraft top injector back in place.
- Using the brush collect the ash in the bottom chamber into the metal pan and empty it.

6.1.2 Cleaning the Glass

It will be necessary to clean the glass after long usage or when improper fuel is burnt. A dampened paper towel newspaper with cool ash or a non-caustic oven cleaner can be used to clean the glass. Do not scrub using steel products or abrasive material, as it can leave scratch marks on the glass and also damage printing on the glass. Do not use

6.1.3 Cleaning the Panels

A soft dry cloth is sufficient to clean and maintain the finish of the panels. Household detergent or a damp cloth must not be used as they may damage painted panels or give bad odors while running the fire.

6.1.4 Visual checks

- Make sure that the top downdraft injector is sitting properly in the top combustion chamber.
- All boards in both the combustion chambers are in place and are in good condition.
- Make sure that the ceramic block in the bottom chamber is sitting properly in the bottom combustion chamber. If the holes of this ceramic block appear to be filled with fly ash, remove it from the bottom chamber and dust off using a soft brush.

6.2 Annual Maintenance

<p>In order to meet consent regulation of the Environment Canterbury Regional Council and Glen Dimplex's warranty terms, Mystique burner must be serviced at least once every 2 years from service agent trained and authorized by Glen Dimplex New Zealand.</p>

To ensure continuous safety, before each heating season, check the condition of the following items; the flue system, the insulating boards in both the top and the bottom chambers, door seals, damper seal, heat exchanger access plate seal. Replace parts only with genuine GLEN DIMPLEX spare components.

6.2.1 Flue Inspection & Cleaning

Flue system should be checked and be swiped by a professional chimney sweep at least once a year depending upon usage. Do not use chemical chimney cleaners. Check the flue sections nearest the firebox. If a flue system is becoming excessively blocked or needs frequent cleaning, investigate the installation, fuel and operation of the burner with help of a professional.

6.2.2 Cleaning of Combustion Chambers and Overall Firebox

Top, Bottom and the upper gas discharge chambers should be cleaned and checked for wear and tear of various components. Areas and parts to look for are:

- Down draft injector
- Insulation boards
- Ceramic block in the bottom chamber
- Top combustion chamber door seal and tape seal behind glass
- Bottom combustion chamber door seal and tape seal behind glass
- Damper seal in the upper exhaust chamber
- Damper mechanism parts inside the upper gas discharge chamber.
- Seal of heat exchanger access plate
- Heat exchanger tubes

Further sections will describe the step by step process of carrying out servicing of different sections of the firebox and the heat exchangers.

6.2.3 Firebox Lining Boards & Ceramic Block

The vermiculite boards in your Mystique burner are an important part of the burner so as to achieve clean and efficient burn. These boards are likely to degrade with time and will need to be replaced accordingly. The life of the boards will depend upon usage, type of fuel burnt and care taken during operations and maintenance. The boards in both the top and bottom chambers are designed to hold them in place by interlocking into one another. Due to high temperature in the fire box, the boards may crack with use and this is regarded as a normal occurrence. If the boards crack but remain in place, it will not affect the performance of the fire and subsequently can continue to be used. The boards should be replaced only when they are damaged enough that they no longer remain interlocked in place and cannot perform their intended task. Refer to the following diagram for location and sequence of assembly of boards in both the top and bottom combustion chamber.

The ceramic block placed in the bottom combustion chamber helps in minimizing fly ash entering the heat exchanger and the main flue pipes. Placing ceramic block in the correct position is important for achieving clean and efficient burning.

After removing the boards and the ceramic block, remove all the ash from both chambers using brush and pan.

6.2.4 Door and Other Seals

Seals in following areas should be checked and if required will need replacement periodically depending upon usage of the Mystique burner.

- Top combustion chamber door seal and tape seal behind glass
- Bottom combustion chamber door seal and tape seal behind glass
- Damper seal in the upper exhaust chamber

6.2.5 Cleaning the Heat Exchanger

Though the ceramic block arrests most of the fly ash, some fine ash particles will enter heat exchanger and condense suite over the period. The heat exchanger should be checked and cleaned at least once a year depending upon usage.

- Open the bottom combustion chamber using tool provided with the fire
- Using hands, carefully pull the ceramic block out of its locator bricks at the rear of the chamber.
- Dust off the ceramic block and place in a safe place.
- Close the bottom combustion chamber door
- Remove the rear top exchanger panel
- Remove the heat exchanger cover plate
- Insert a long wire brush through this opening to clean the outer surfaces of all the tubes.
- The ash will fall down at the base of the heat exchanger.
- Open the bottom combustion chamber door
- Using a metal pan and a small brush collect the ash and dispose of at a safe place.
- Close the heat exchanger cover plate and screw back the rear panel
- Put ceramic block in the bottom combustion chamber and make sure it is pushed correctly at the rear.

7.0 Electrical Parts and Electronic Control

- All the electrical and electronics components of Mystique burner are preassembled at the factory.
- Only certified electrician should remove the electrical and electronics components to carry out fan installation, servicing and maintenance.
- For electrical installation work related to this burner, a Certificate of Compliance (COC) should be obtained from the electrician

7.1 Fan Operation

- Keep the fire connected to power supply all the time and fan switch "ON" all the time.
- Fan will switch "On/Off" automatically as per set temperatures of the rear of the firebox.
- Please note that in case of emergency and power outage situations, burner can be operated without fan.
- While running the burner without power, there will be no LED to indicate that the firebox has reached optimum conditions for down draft mode. Hence ensure that damper handle is turned to "Close" position approx. 15 mins after the light-up, which is the optimum point for switching.

7.2 Fan Maintenance

The fan should need little attention other than removing it to clean the dust and lint from the impeller at least once a year. Depending upon usage and environment, dust cleaning may need more than once a year

- **First isolate the fan from the power supply.**
- Open the bottom combustion door using tool supplied.
- Remove the front panel by unscrewing two screw on the front face behind bottom door.
- Disconnect all the fan connection and remove the fan assembly out of pedestal area.
- Clean the impeller blades carefully by blowing or vacuuming, and reassemble in the reverse order.
- **If any part or section of the wiring is damaged, it must be replaced with complete loom supplied by Glen Dimplex in order to avoid a hazard.**

7.3 Electronic Control

For any malfunction or trouble shooting, contact retailer where you bought your Mystique burner or your nearest Masport heating specialist or Glen Dimplex Customer Service department on 0800 666 2824

7.4 Electrical Schematic Diagram

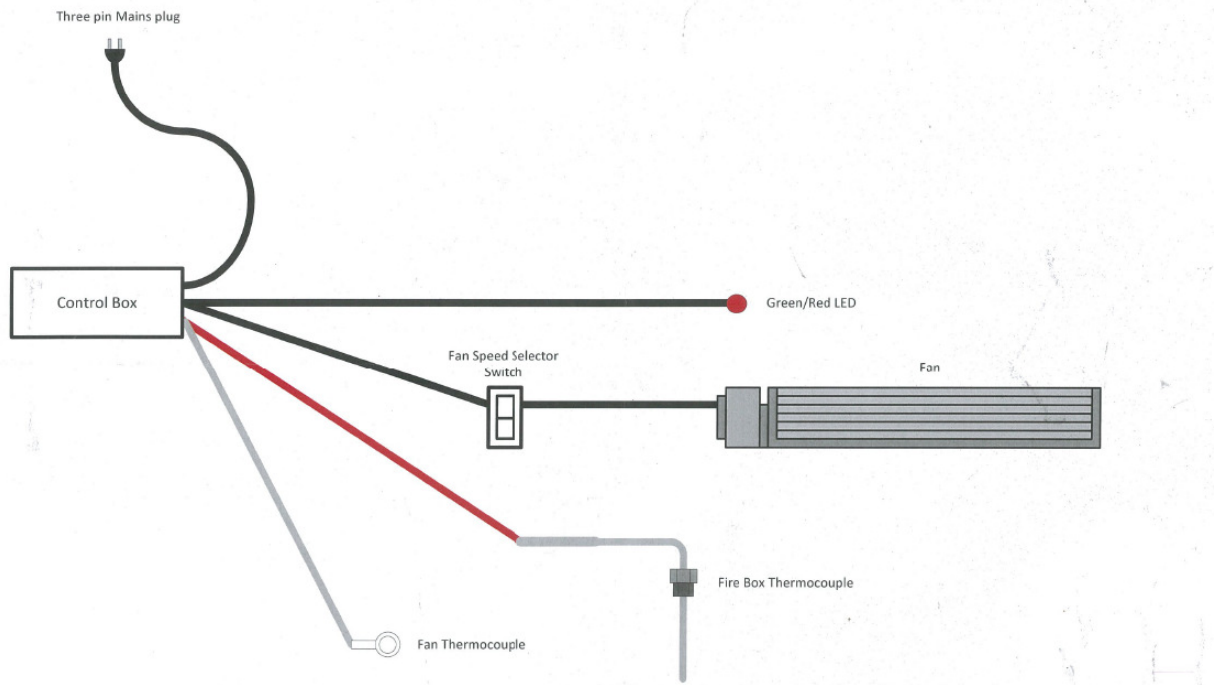

7.0 Mystique Replacement Parts

Some parts of Mystique burner are considered consumable. These parts will wear out or degrade over time. The life of these parts will vary upon

- How frequently the fire is used
- Type of fuel. Some species of wood fuel are harsher than others.

Following items are considered as consumables.

Boards & Bricks

- Set for Top Combustion Chamber
- Set for Bottom Combustion Chamber
- Ceramic Block

Seals

- Top Door Seal
- Bottom Door Seal
- Damper Seal

Glass

- Top Combustion Door Glass
- Bottom Combustion Door Glass

Downdraft Injector

- Top Downdraft Injector
- Injector Coupler

These consumable parts should be replaced as soon as they show signs of wear. Running your burner with worn or broken parts may result in reduced output, increase in fuel consumption and even can damage the firebox or other vital parts of the burner. We highly recommend frequent visual check of these consumables and other parts of the burner.

Other Spare Parts

Electrical & Electronics

Convection Fan
Electronic Controller
Electrical Looms
Thermocouple 1
Thermocouple 2

Other

Top Door Handle Kit
Bottom Door Handle Kit
Damper

Refer Fig 7.1 & Fig 7.2 for schematic of Mystique parts and Insulation Board layout.

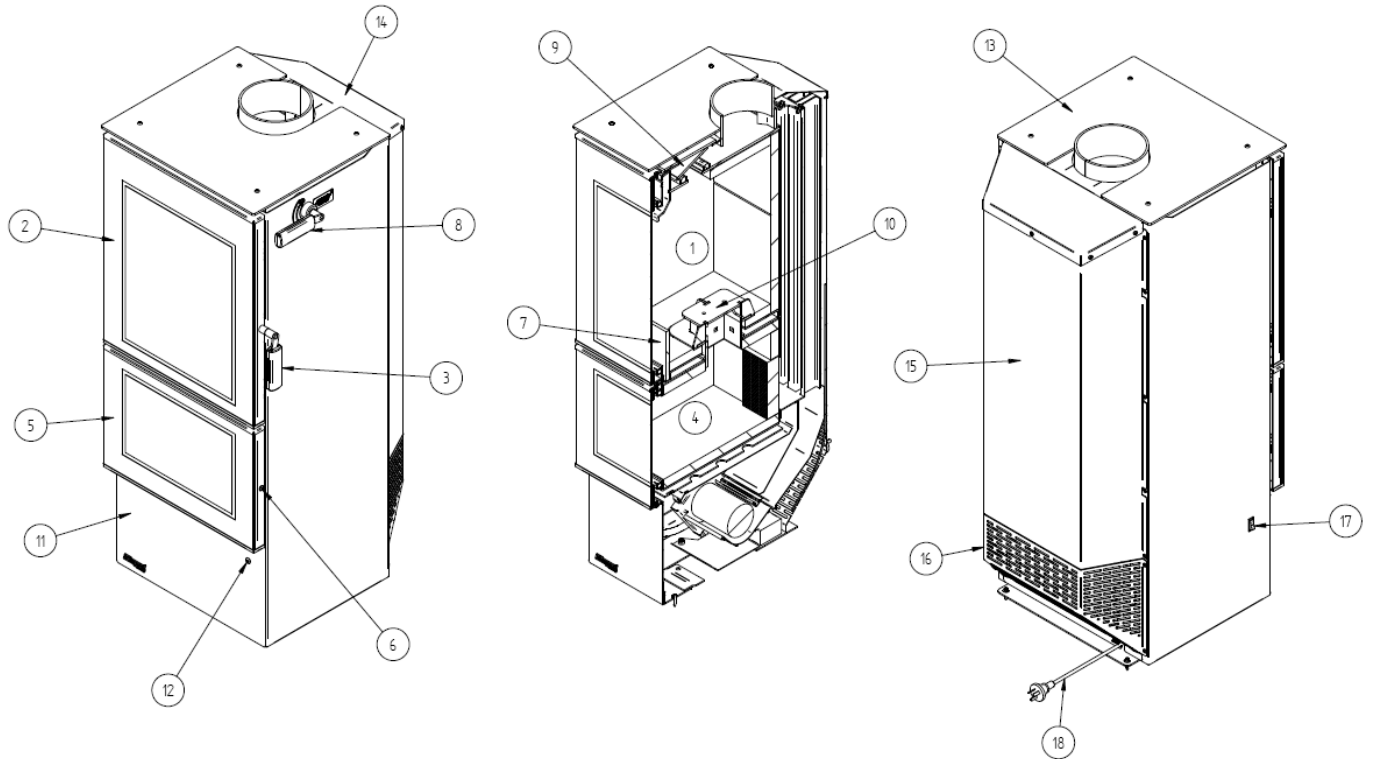

Fig 7.1

Part Description		Part Description	
1	Top Combustion Chamber	10	Down Draft Injector
2	Top Combustion Chamber Door Complete	11	Bottom Front Panel
3	Top Door Handle	12	RED/GREEN LED - Damper Location Indicator
4	Bottom Combustion Chamber	13	Top Plate
5	Bottom Combustion Chamber Door Complete	14	Heat Exchanger Access Panel
6	Bottom Door Access Screw	15	Rear Panel
7	Top Chamber Ash Glass	16	Bottom Rear Fan Grill
8	Damper Handle	17	Fan Switch
9	Damper Plate	18	Power Lid

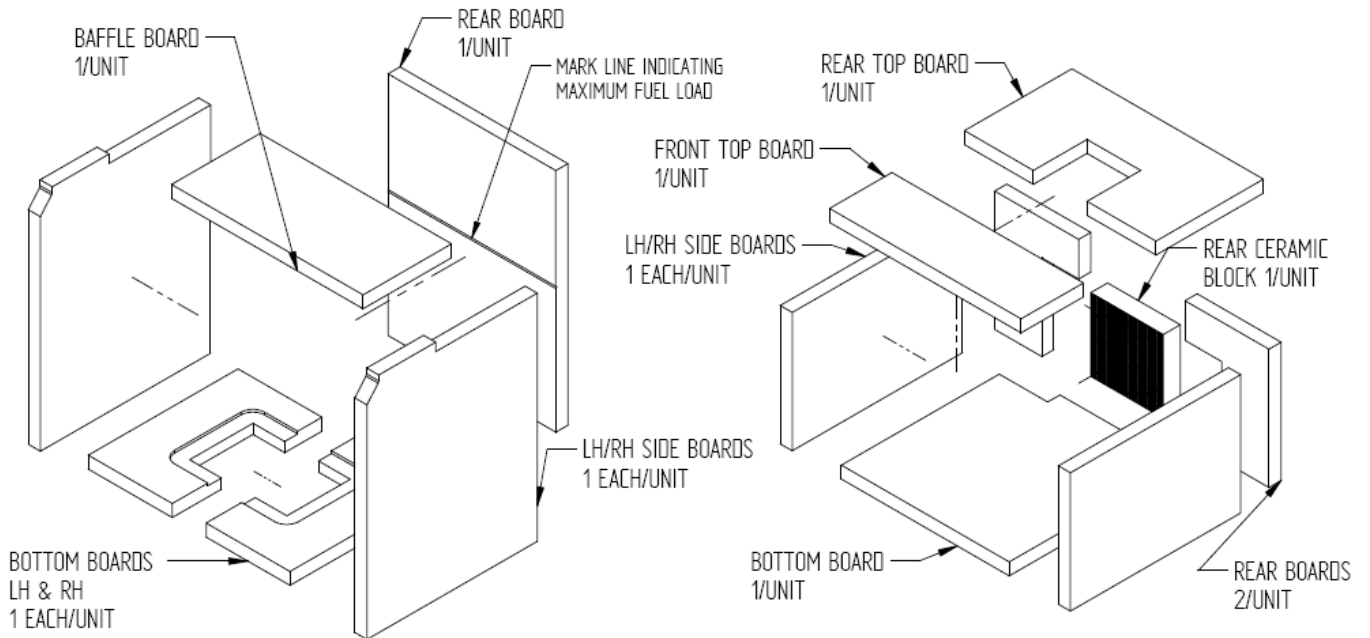

Fig 7.2

8.0 Problem Solving

Problem	Reason for Problem	Solution
Dark, dirty film on door glass	Burning wet or green firewood OR Leaking door seals.	<p>Ensure only dry seasoned wood is used. As per new air plan, it is an offence in the Environment Canterbury region to burn wood with greater than 25% moisture.</p> <p>Check door and glass seals. Your Masport Dealer can help with this.</p> <p>To remove dirty film try following:</p> <ol style="list-style-type: none"> 1. Burn with damper open for 30 minutes. 2. Try to clean glass with damp news paper and ash when fire has completely cooled down 3. Try using non-caustic oven cleaner <p>Caution: Do not scrub using steel products or abrasive material, as it can leave scratch marks on the glass and also damage printing on the glass.</p>
Occasional puffs of smoke entering the room while fuel loading	<p>There could be not enough flue draft due to insufficient flue height in relation to your roofline, trees or other high obstacles near your home, which can cause a down draft.</p> <p>The fuel will eventually ignite and when it does so, the build up of gasses will cause a pressurisation forcing smoke into the room.</p>	<p>Mystique burner has mechanical interlock that prevents opening of top combustion door unless damper is opened. After switching damper handle from "OPEN" to "CLOSE" position, wait for 30~45 seconds before you open the top combustion chamber door.</p> <p>This is usually a problem when the wind is coming from one particular direction and requires an experienced installer to remedy, by either extending your flue height or fitting an anti down draft flue cowl.</p>
The down draft flame is pulsing or puffing when damper is switched to 'CLOSE' position	<p>This is likely to happen when firing the burner from cold start.</p> <p>Not enough embers around the downdraft injector can be another reason.</p>	<p>Open the damper for 1~2 min and close it.</p> <p>Open the damper and then the top combustion chamber door and using rake, level the ember bed. Particularly leaving good embers around the downdraft injector</p>
Poor performance of the fire or Smoke entering into room due to extreme negative pressure in the house	<p>This is when the air circulates down from the chimney towards the interior of the house which is at negative pressure.</p> <p>Energy efficiency practices and new building code rules are making our houses more and more airtight. This makes the house's energy efficient but also makes them more sensitive to negative pressure when air is exhausted from the house. This can be because of large extraction fans which cause extreme negative pressure in the house when they are operating.</p> <p>This negative pressure works against flue system draft. In severe cases the negative pressure in the house overcomes the flue system draft and the appliance begins to spill smoke, especially when a fire is started or when it dies down to coals. Also it can starve fire from air needed resulting in poor performance.</p>	<p>To prevent this extreme negative pressure open a window approximately 6mm to allow combustion air enter into the room.</p>

GLEN DIMPLEX WARRANTY REGISTRATION

MYSTIQUE ULTRA LOW EMISSION BURNER

Thank you for purchasing a Masport Fire. We ask you to complete the following information and return to the Glen Dimplex Warranty Registration Department on following address:

New Zealand : P O Box 58473, Botany, Manukau 2163, Auckland
Australia : Unit 1, 21 Lionel Road, Mount Waverley, Victoria 3149

Mr / Mrs / Miss / Ms Name: _____

Address: _____

Post Code: _____

Telephone: _____ Fax: _____

Email _____

Model: _____ Serial Number: _____

Retailer: _____ Purchase Date: _____

Price: _____

Installed By: _____ Date Installed: _____

We at Glen Dimplex strive to provide you with quality products and have continuous product development program. To help achieve our objectives to our mutual benefit we would welcome your feedback on the following questionnaire.

Question	Please tick appropriate remark			
1.General presentation of Product	<input type="checkbox"/> Excellent	<input type="checkbox"/> Good	<input type="checkbox"/> Ok	<input type="checkbox"/> Needs to Improve
2.Styling and Looks	<input type="checkbox"/> Excellent	<input type="checkbox"/> Good	<input type="checkbox"/> Ok	<input type="checkbox"/> Needs to Improve
3.Packaging	<input type="checkbox"/> Excellent	<input type="checkbox"/> Good	<input type="checkbox"/> Ok	<input type="checkbox"/> Needs to Improve
4.Is documentation easy to follow and informative?	<input type="checkbox"/> Excellent	<input type="checkbox"/> Good	<input type="checkbox"/> Ok	<input type="checkbox"/> Needs to Improve
5.Fixtures & Fittings (Loose parts)	<input type="checkbox"/> In order	<input type="checkbox"/> Items missing	<input type="checkbox"/> Needs to Improve	
6.Do you currently own Masport or Dimplex product?	<input type="checkbox"/> Yes	<input type="checkbox"/> No	Which? -	
7.Why did you decide on Masport? (tick one or more options)	<input type="checkbox"/> Knew this brand		<input type="checkbox"/> Suggested by Friend	
	<input type="checkbox"/> Dealer recommended		<input type="checkbox"/> Better Price	
	<input type="checkbox"/> Performance		<input type="checkbox"/> Features	
8.Other Comments	_____			

Privacy Act Notice: the owner named on the Warranty Registration consents and agrees that Glen Dimplex may retain and use the information in this warranty card, including details about the owner for marketing and development purposes. The owner also agrees that Glen Dimplex may also share purposes with [intended recipients of such information]. In accordance with the New Zealand Privacy Act 1993 and the Australian Privacy Act 1988, the owner shall have the right to request the correction of, as well as inspect, all personal information held by Glen Dimplex on that owner.

**Please cut and mail this completed form within 30 days of installation to your
 Glen Dimplex Warranty Registration Department at the above address**



WARRANTY FOR MASPORT MYSTIQUE ULTRA-LOW EMISISON BURNER

This warranty is provided in New Zealand by Glen Dimplex New Zealand Ltd and in Australia by Glen Dimplex Australia Pty Ltd. (together referred as “Glen Dimplex”)
 This warranty is provided to the first domestic purchaser of a Masport wood or multi-fuel fire (radiant or convection). It applies from the date of purchase from or through an authorized Masport Fire Distributor in relation to each product or component for the period below.

TYPE OF PART	WARRANTY (In Years)	
	PARTS	LABOUR
BURNER's STEEL FIRE BOX	5	3
DOOR GLASS & SEAL	1	1
VERMICULITE BOARDS	1	1
DAMPER COMPONENTS	1	1
GLEN DIMPLEX FLUE SYSTEM	1	1
FANS & ELECTRICAL COMPONENTS	1	1

During the warranty period, Glen Dimplex will repair or replace (at its option) any Masport Wood Fire which is found to be defective in materials or workmanship. Repairs will be carried out by an approved Masport Heating Service Agent.

What is covered under this warranty?

- Repair or replacement of parts
- Labour costs relating to the Wood Burner
- Reasonable transport or travel costs.

Consumers may have additional rights under the Consumer Guarantees Act 1993 (New Zealand) or the Australian Trade Practices Act 1974 including the Australian Consumer Law.

Conditions

This warranty does not apply and will be void where:

- The Wood Burner is not installed in accordance with AS/NZS2918/:2001 or any building code or consent;
- The Wood Burner is not installed by a qualified specialist installer;
- Any electrical work has not been carried out by a Registered Electrician;
- The Wood Burner has been moved and reinstalled, or has been modified in a manner that is not consistent with the Installation Guide or the Owner's Manual;
- The Wood Burner has not been installed, operated or maintained according to the Installation and Operations Manual;
- The Wood Burner is acquired for business use in any way.

What is not covered?

- Wear and tear, including wear and tear through normal use on Multi-fuel fire grates and cast iron fire box liners.
- Labour costs relating exclusively to components not manufactured by Glen Dimplex.
- Damage caused by incorrect use or the burning of treated or painted wood, driftwood or other fuels which are not recommended;
- Travel costs for a distance greater than 50 km from the nearest approved Masport Heating Service Agent. (The location of the Wood Fire must be advised to Glen Dimplex or its sales agents at the time of purchase or using warranty registration form)
- Defects, malfunctions or failures caused by incorrect installation, poor installation, normal wear and tear, misuse, neglect, accidental damage or failure to follow operating instructions in the Owner's Manual (including fuel selection, product operation and maintenance instructions), repairs or modifications by persons not authorised by Glen Dimplex, use of parts not supplied by Glen Dimplex, or damage or other events which have occurred since the product left the control of Glen Dimplex.
- Direct, indirect or consequential losses or special damages of any kind (including costs of collection and delivery) other than repair or replacement of products or components under this warranty, where any goods are acquired or used for the purposes of a business;

How to obtain warranty service?

- Completed Warranty registration form (previous page) needs to be mailed within 30 days of installation to your Glen Dimplex Warranty Registration Department.
- Warranty Claims must be made at place of purchase.
- Reasonable proof of purchase date is required to make a warranty claim. You should keep your purchase receipt.
- Warranty repair will be completed according to normal work practices of the service agent.
- Make the faulty part(s) available to Glen Dimplex for inspection so that the validity of the claim can be established by them.

Manufactured in New Zealand by: GLEN DIMPLEX NEW ZEALAND LTD

NZ Registration No – 1506305

P.O.Box 58473, Botany,

Manukau 2163

Phone: 0800 666 2824

Fax : 09 274 8472

Email : sales@glendimplex.co.nz

Web : www.glendimplex.co.nz

*Glen Dimplex New Zealand Ltd reserves the right to change specifications, content of this manual or design of its product without prior notice.